

Product List

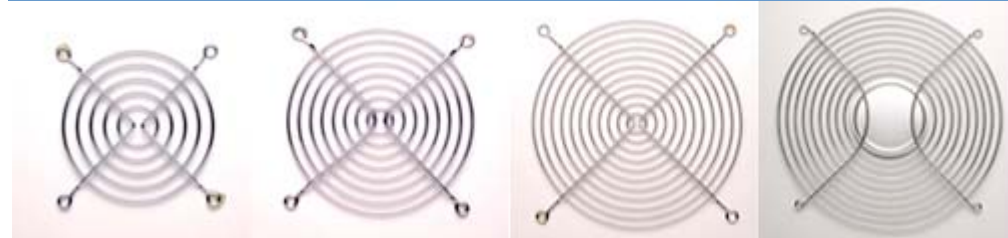

Metal Fan Guard

- Steel wires, electroplated finish cosmetics, nickel chrome plated, bright color.
- Black color electro deposit available on request .
- Welding joints strength to meet UL Standards minimum 100kgs (220 lbs) separation force.
- Patterned push-on type wire form metal guards are available on request.
- Customer's design is acceptable & welcome!

TWG-25 for 25mm
Standard Type

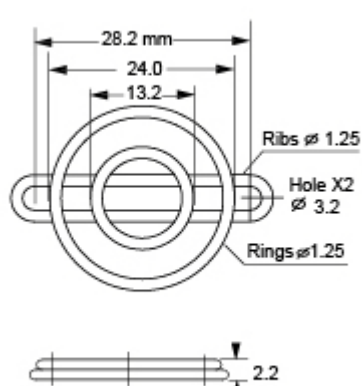

TWG-40 for 40mm

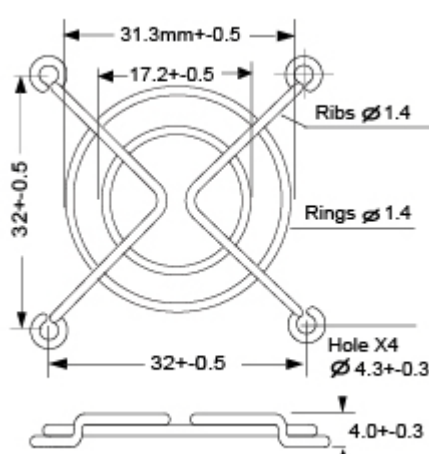

TWG-45 for 45mm
Special Type

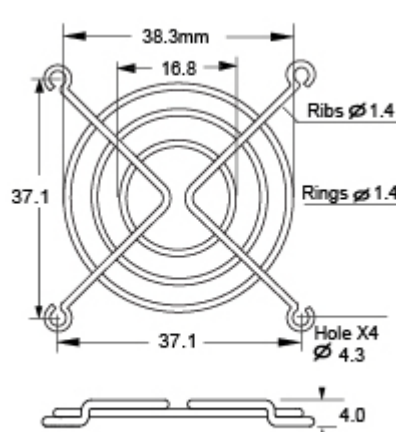

TWG-50 for 50mm
Standard Type

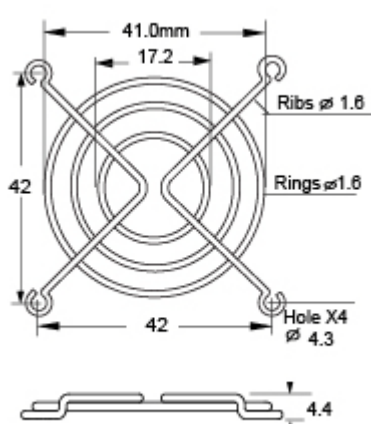

TWG-60 for 60mm
Standard Type

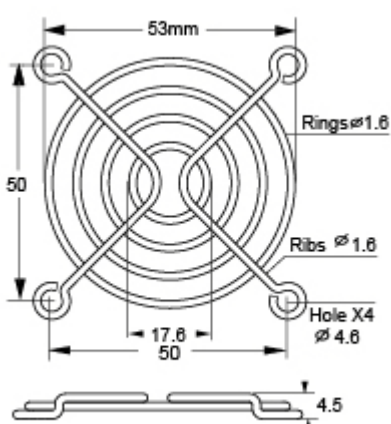

TWG-60F for 60mm
Flat Type, Standard Type

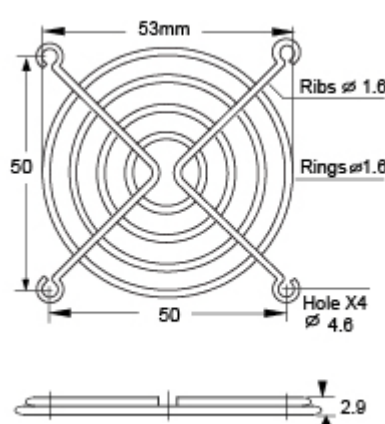

TWG-60 for 60mm
2 Ring Raised Type, Special Type

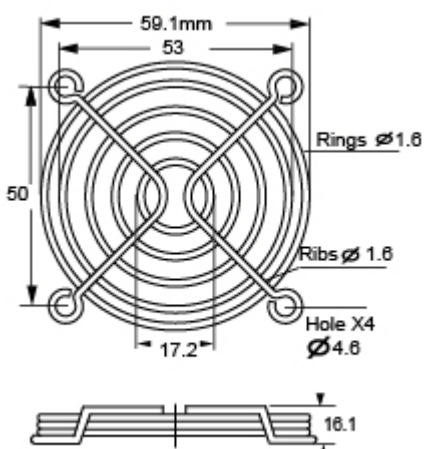

TWG-60 for 60mm
2 Rib Type, Special Type

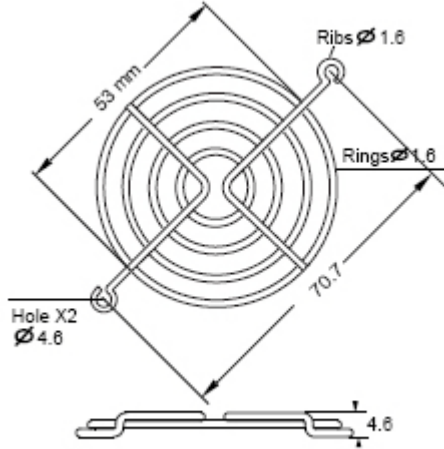

TWG-70 for 70mm
Standard Type

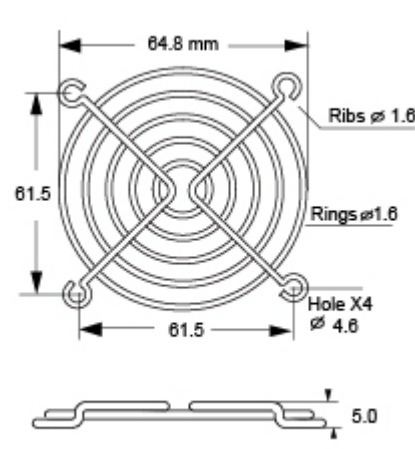

TWG-80 for 80mm
Standard Type

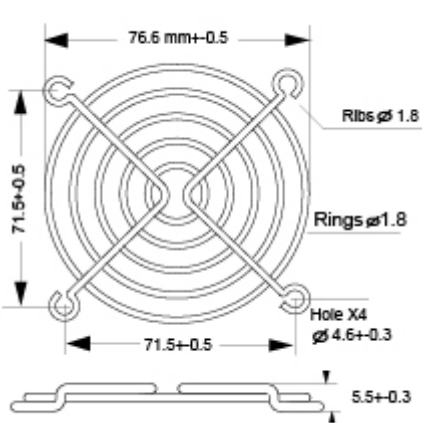

TWG80-1 for 80mm
Special Type

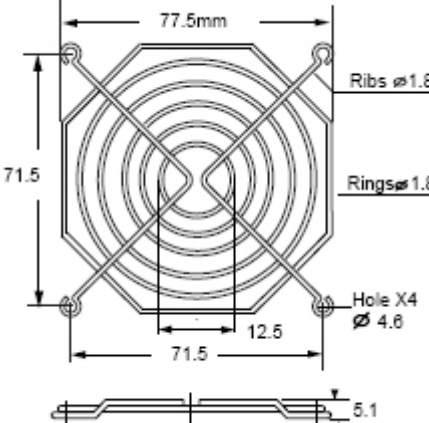

TWG80-2 for 80mm
2 Ring Raised Type, Special Type

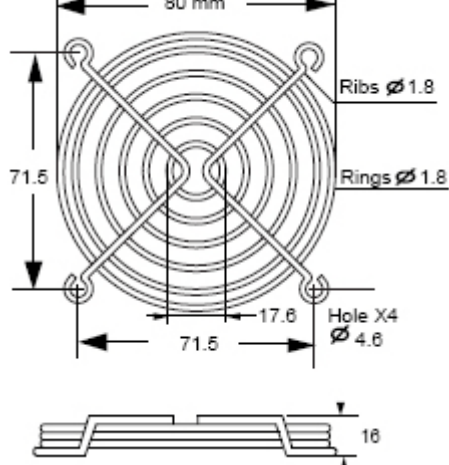

TWG-80F for 80mm
Flat Type, Special Type

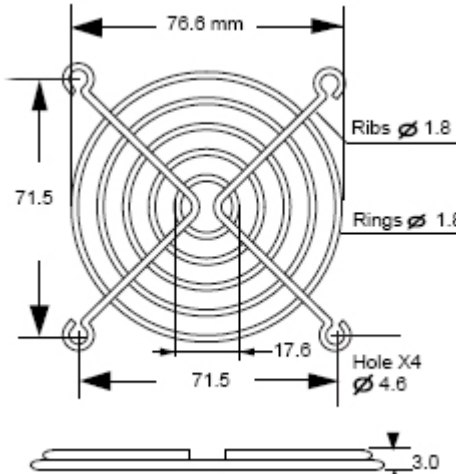

TWG-80-2 for 80mm
2 Rib Type, Special Type

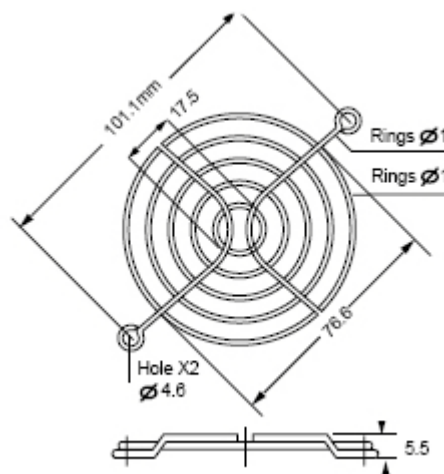

TWG-92 for 92mm
Standard Type

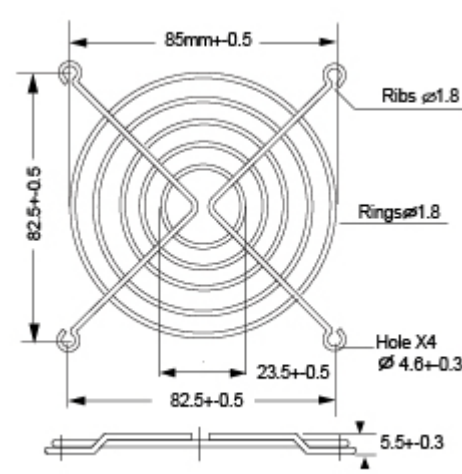

TWG-92-1 for 92mm
Standard Type

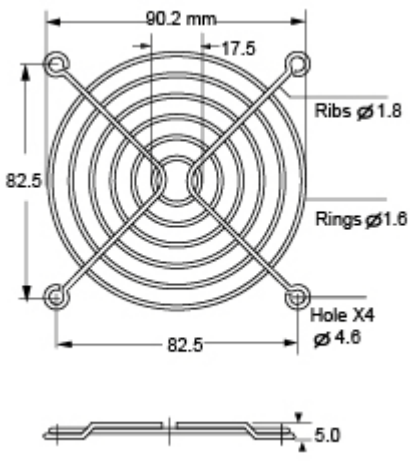

TWG-92F for 92mm
Flat Type, Special Type

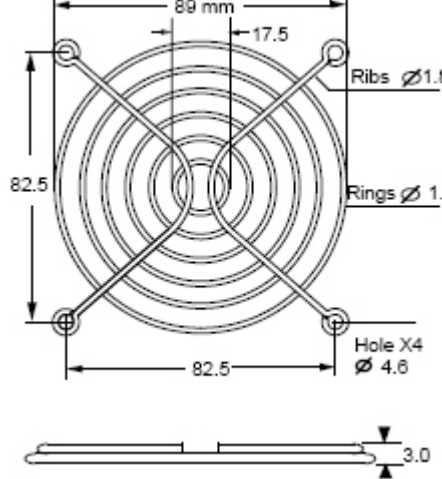

TWG-92-2, for 92mm
2 Rib Type, Special Type

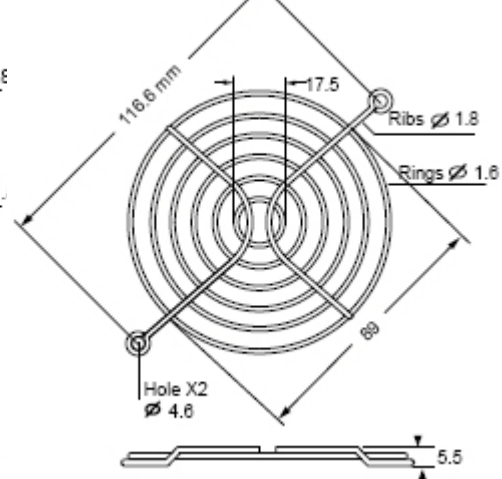

TWG-120 for 120mm
Standard Type

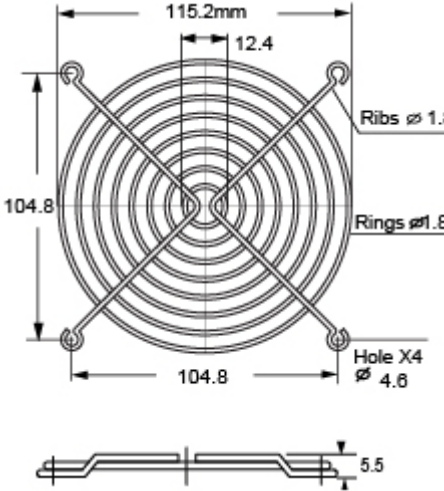

TWG-120-5 for 120mm

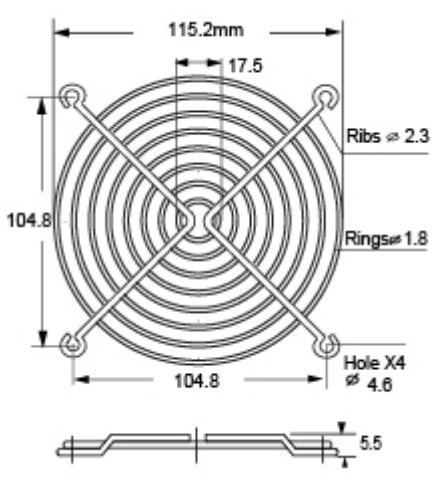

TWG-120-2 for 120mm
2 Rib Type, Special Type

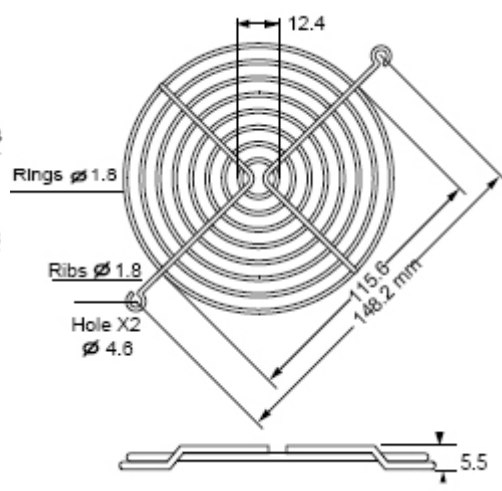

TWG-120-C, for 120mm

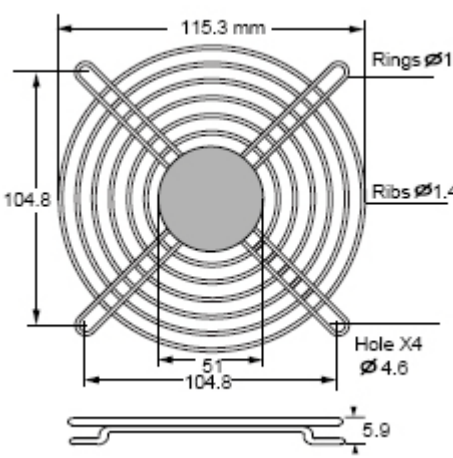

TWG-120-S, for 120mm

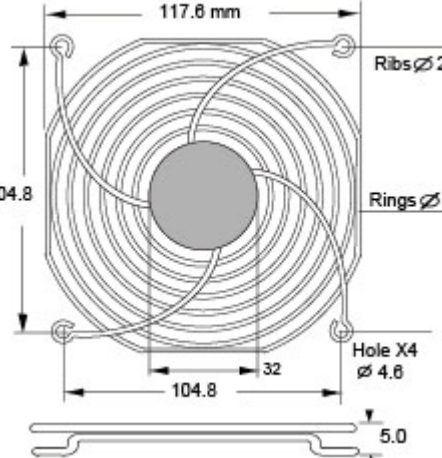

TWG-120-E, for 120mm
Fan Special Disk Type

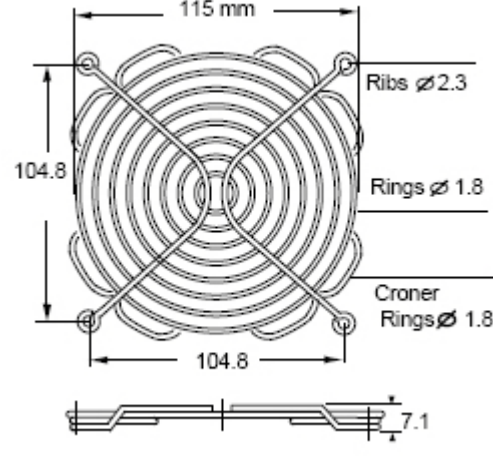

TWG-120-8R2 for 120mm
2 Ring Raised Type, Special Type

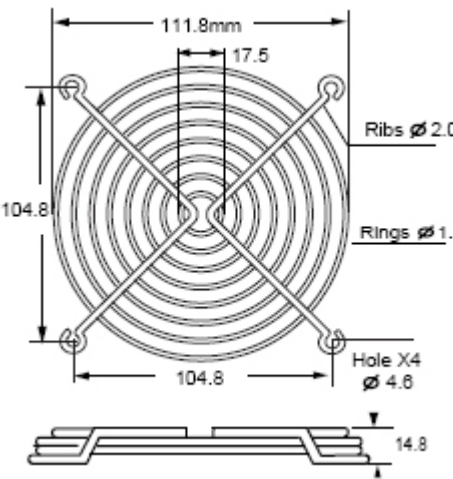

TWG-120-8R3, for 120mm
3 Ring Raised Type, Special Type

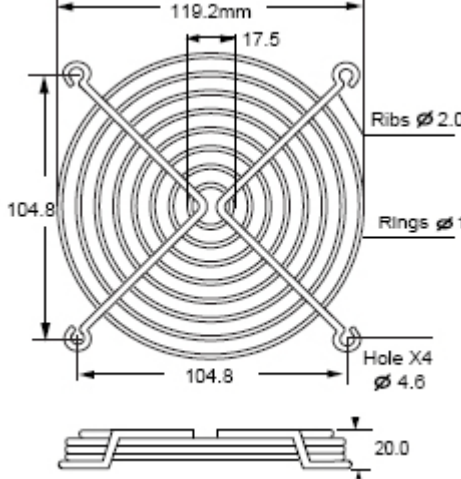

TWG-120-15C for 120mm
Special Type

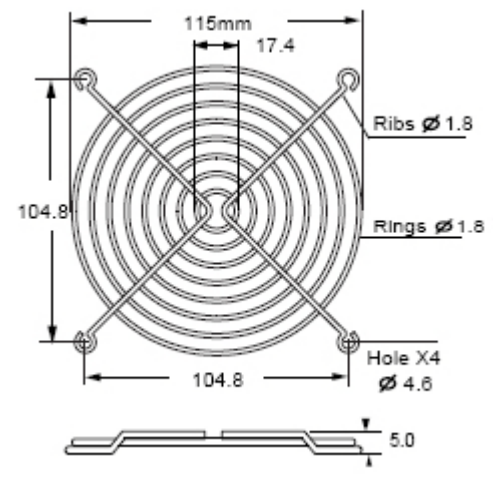

TWG-120-15CF, for 120mm
Flat Type, Special Type

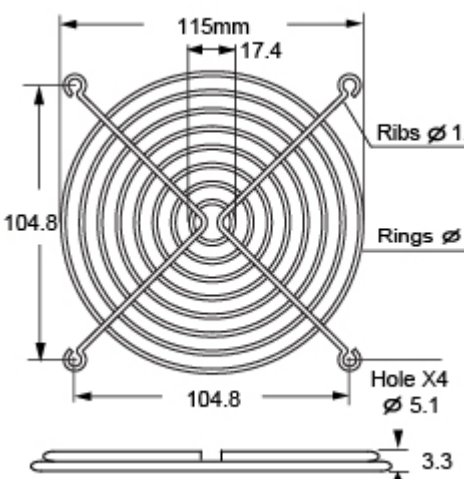

TWG-120-17 for 120mm
Standard Type

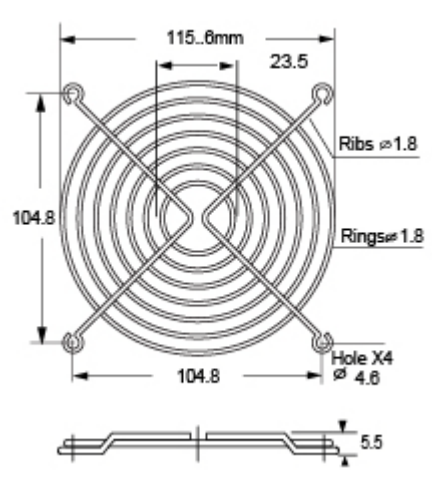

TWG-127 for 127mm
Standard Type

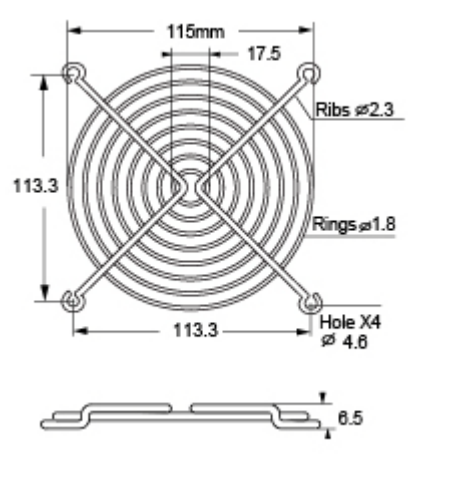

TWG-127-9E for 127mm
Special Type

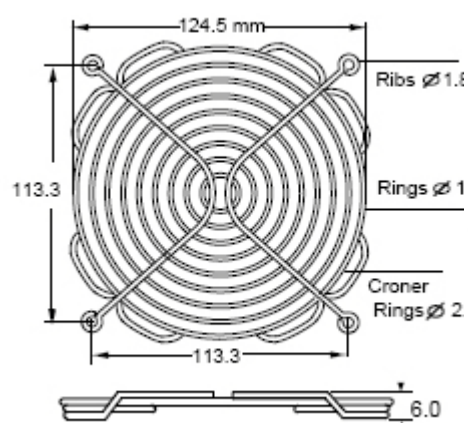

TWG-127-82 for 127mm
2 Rib Type, Special Type

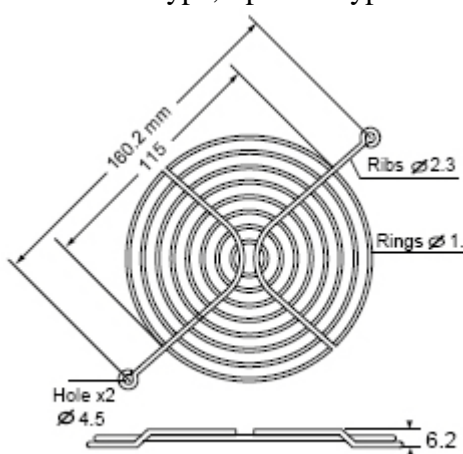

TWG-172-6H for 172mm fan
Standard Type

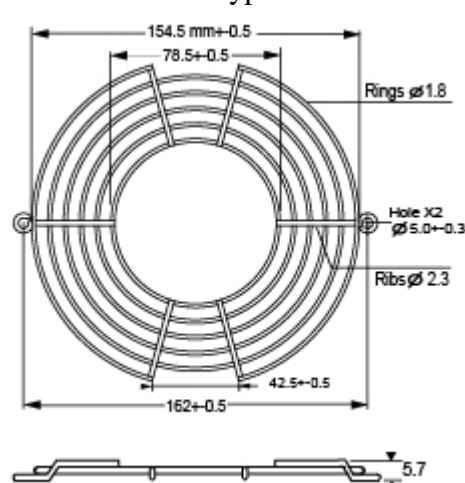

TWG-172-10H for 172mm
Standard Type

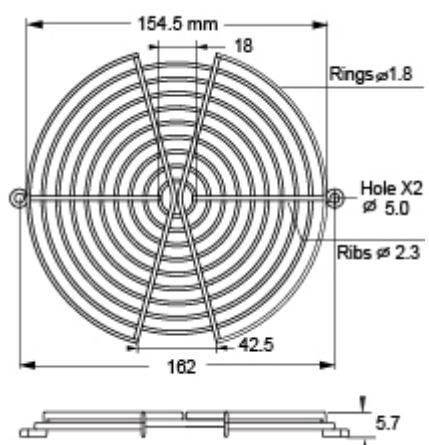

TWG-172-10HA for 172mm
Standard Type

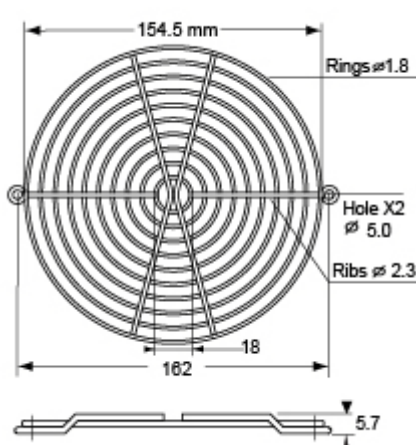

TWG-172-10A for 172mm
Special Type

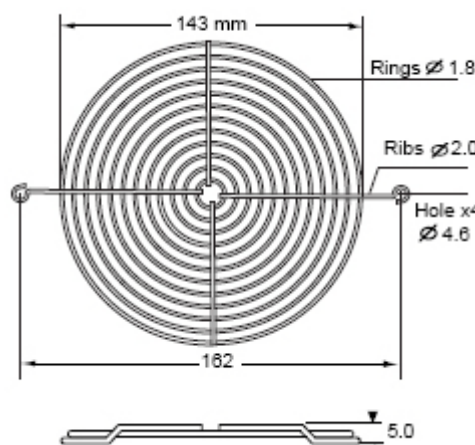

TWG-172-10S for 172mm Fan
Special Type

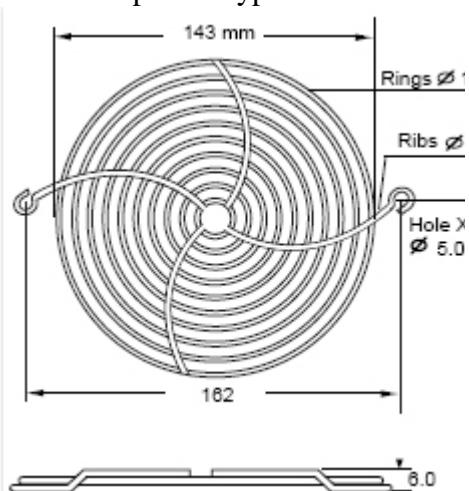

TWG-172-7DU for 172mm
Center Disk Type, Special Type

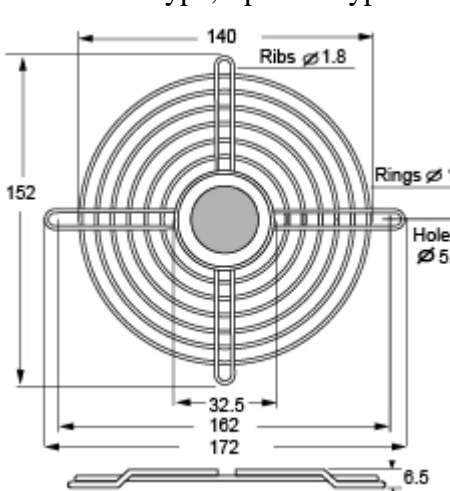

TWG-180 for 180mm Fan
Standard Type

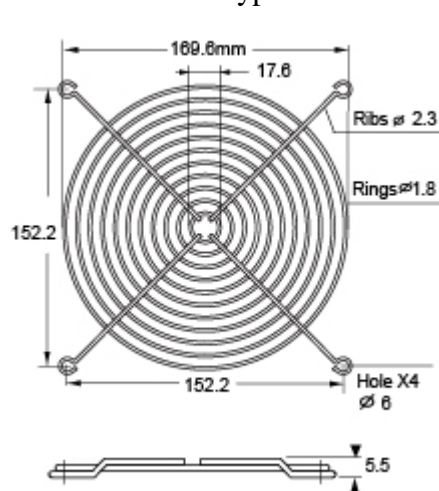

TWG-200 for 200mm Fan
Standard Type

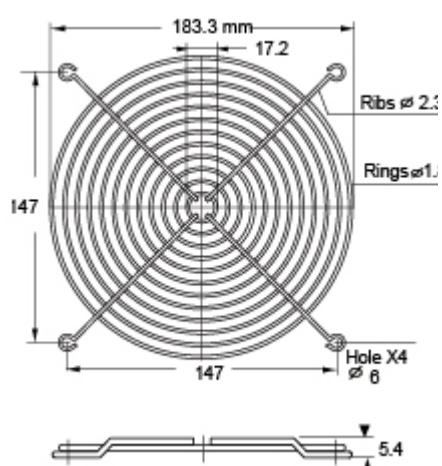

TWG-205 for 205mm
Standard Type

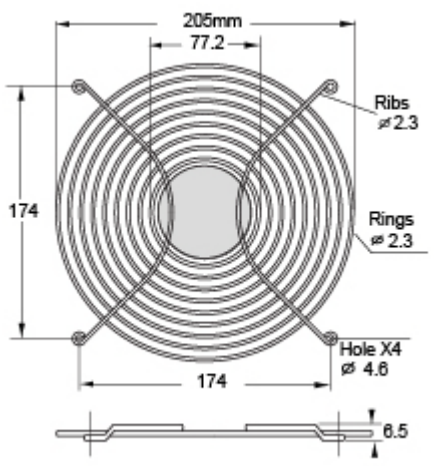

TWG-205-6, for 205mm
Standard Type

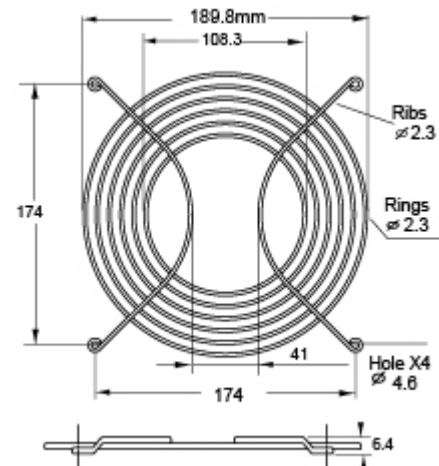

TWG-254 for 254mm
Center Disk Type, Standard Type

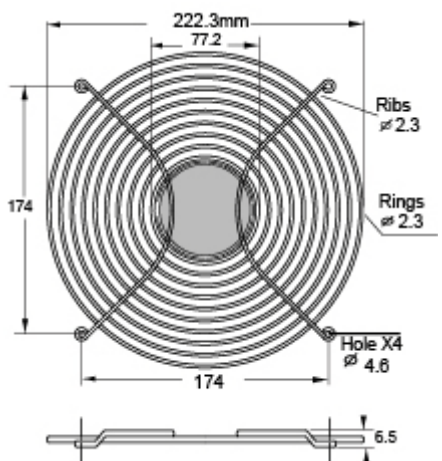

TWG-254-9DU for 254mm
Standard Type

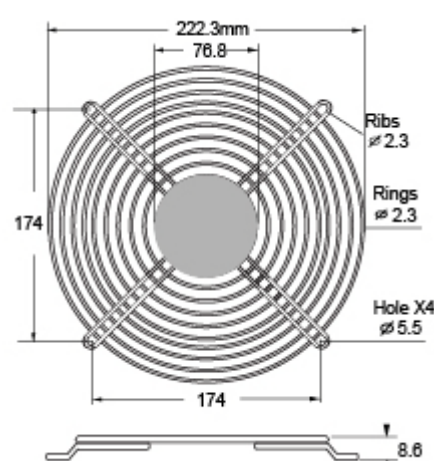

TWG-280 for 280mm
Standard Type

